

Fact Sheet

iL Special 50S/SP

The iL Special 50S/SP is a special solution for the sausage production: Combined with weighing terminal iS30 the load receptor becomes a precise smoke stick scale. Combined with your sausage filler the system reliably controls the product weight. Two load receiving bars simply hold the smoke sticks (sausage portions). You also reliably weigh individual sausages with the weighing tray.



More information
High performance
with a wide range of
solutions and options.

Specifications	Facts	Details
Weighing ranges	12 kg / 2 g	Not verifiable
	15 kg / 5 g	Not verifiable
Load cell	PC6 C3 50 kg	
Dimensions	Mounting to existing column	Depending on the mounting position of the weighing terminal and load receptor
	L x H x W	
	390 x 630 x 556 mm	Version wall mount
	705 x 1430 x 713 mm	Version mobile stand
Materials	Mechanics: Stainless steel	1.4301
	Load cell: Stainless steel	
IP rating	IP68	
Ambient temperature	-10 °C to +40 °C	Operation
	-50 °C to +85 °C	Storage
Weighing terminal	iS30	Weighing terminal must be additionally configured
Options	Facts	Details
Wall assembly	Wall mount stainless steel	
Floor mount	Stand stainless steel 1.4301	– Handle and castors for mobile use
		– Foot screws for leveling
Weighing tray	Length: 400 mm	– Stainless steel 1.4301
		– To support individual sausages

Info graphics



Symbols



IP68 protection



Stainless steel

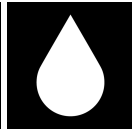

Hygienic design

Dimensional drawings

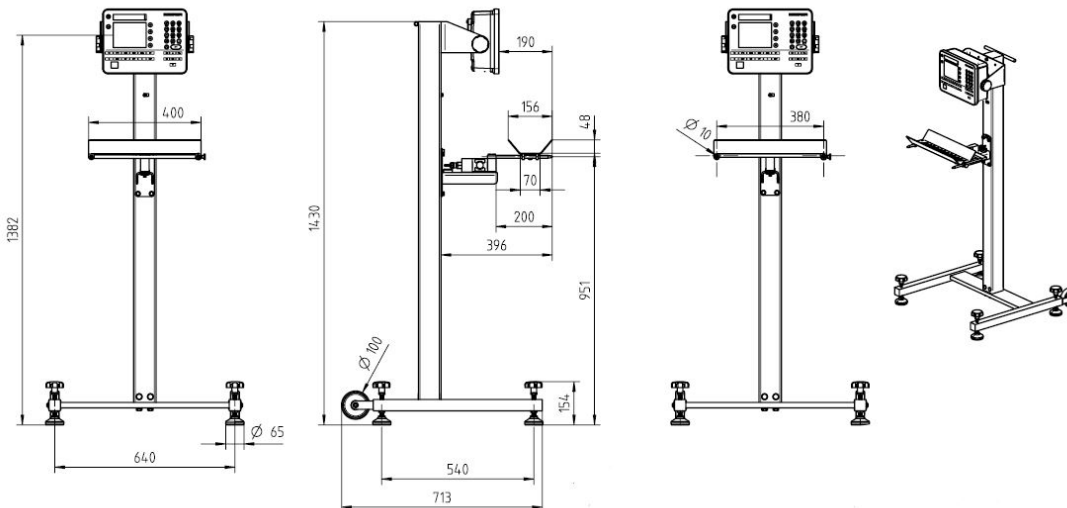

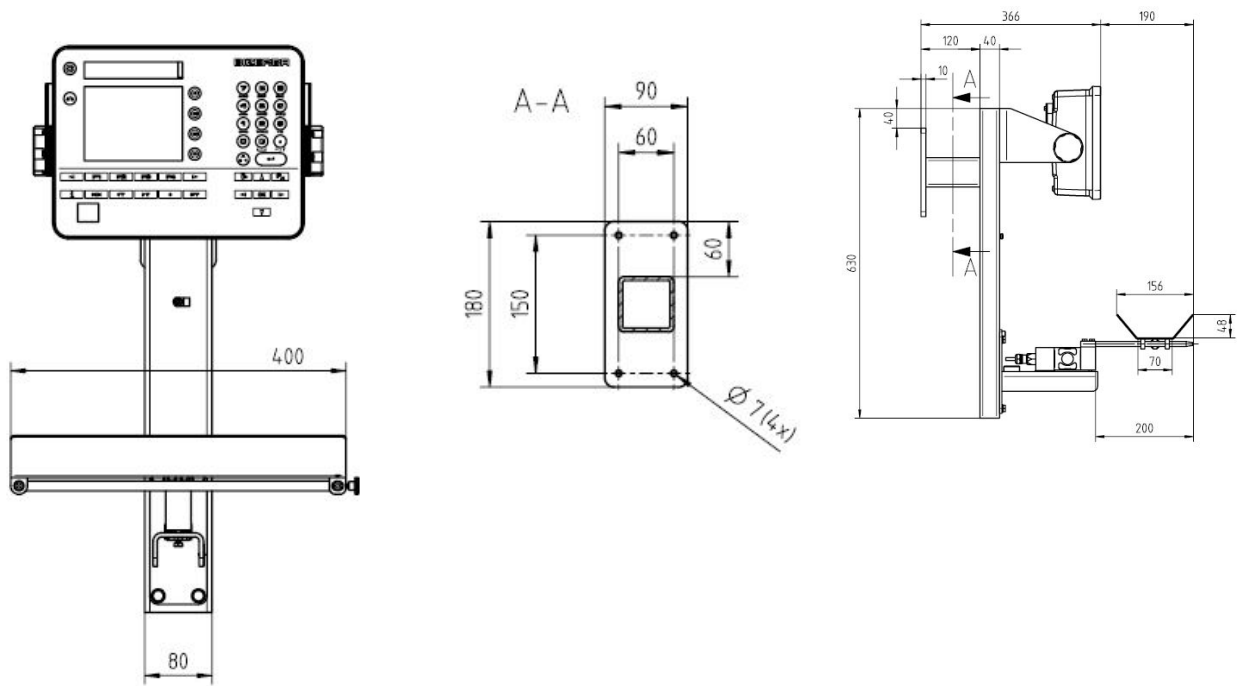

Bizerba SE & Co. KG
 Wilhelm-Kraut-Straße 65
 72336 Balingen

phone: +49 7433 12-0
 fax: +49 7433 12-2696
 marketing@bizerba.com

www.bizerba.com